



# MOBILITY 20G

2x2 MIMO 5G-Ready Cellular Antenna System with GPS antenna

## Overview

- Built for 5G**  
 2x LTE/5G omni-directional antenna for the best performance.
- Ultra-wide bandwidth**  
 Wide frequency range (600-6000MHz) supports LTE and 5G connectivity.
- Robust design**  
 IP68 rated, rugged, low profile and durable housing in Black or White color options.
- Easy installation**  
 Ground plane is not required for installation. Simple panel, wall or pole installation for various applications.

## Applications

- Public Safety and mission critical connectivity
- Mobile Healthcare
- Transportation Connectivity

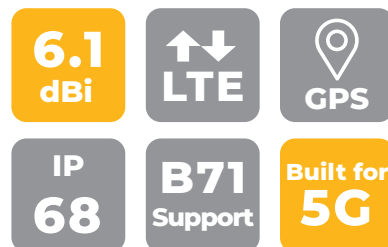

## Specifications

### Cellular

Antenna elements	2 elements
Cellular frequencies	1.0dBi: 617-960MHz 5.6dBi: 1710-2700MHz 6.1dBi: 3400-4200MHz 5.3dBi: 4900-6000MHz
Cellular bands	LTE bands B1 to B86 (except B31, B72, B73, B87, B88), 5G bands n1 to n99
VSWR	< 2.5 over 85% of the band
Feed power handling	10W
Input impedance	50 Ω
Polarisation	Linear
Ground plane	Not required #

### GPS

Frequency range	1561-1602 MHz
Peak gain	0.5dBi@1575MHz 1.6dBi@1602MHz
VSWR	< 2 dB
Output return loss	10dB max
Gain: LNA	28 ±3dB
Noise figure	1.5dB max at 3.3V
Operating Voltage	3.3V
Power consumption	8.5 ±2.5mA at 3.3V

### Cable (LTE / 5G)

Type	CFD-200
Loss	0.33 dB/m @ 900MHz 0.49 dB/m @ 2000MHz 0.55 dB/m @ 2500MHz 0.87 dB/m @ 5800MHz
Diameter	13/64" / 5.0mm
Jacket	Half matt PVC, UV resistant
Cellular Termination	QMA male, SMA male

### Cable (GPS)

Type	RG-174
Loss	3.40 dB/m @ 1000 MHz 4.90 dB/m @ 1800 MHz
Diameter	0.1" / 2.7mm
Jacket	Half matt PVC, UV resistant
Cellular Termination	QMA male, SMA male

### Mounting

Supported types	Panel, wall, pole
Mounting hole	1 11/16" / 43mm
Max panel thickness	19/32" / 15mm

### Mechanical

Product dimensions	(Height) 1.42" / 36mm (spigot not included) (Diameter) 5.12" / 130mm
Package dimensions	8.90"x8.46"x4.29" / 226x215x109mm
Radome material	UV stable PC

### Package contents

Antenna	Mobility 20G
Accessories	Wall/pole mount Double sided 3M adhesive pad (Diameter: 5.08" / 129 mm Thickness: 0.08" / 2 mm)

### Environmental, compliance

IP rating	IP68
Operating temperature	-40° - 176°F / -40° - 80°C
Storage temperature	-40° - 176°F / -40° - 80°C
Compliance	RoHS, REACH, WHEE
Wind Survivability	137mph, 220 km/h
Enclosure flammability	UL 94 HB
Cable flammability	UL 758 (VW-1)
UV resistance	UL 746C (F1 long-term UV exposure)
Salt Spray	MIL-STD 810F/ASTM B117

# Mobility 20G

#All measurements stated in this document were obtained without a ground plane.

## Ordering information

### Mobility 20G

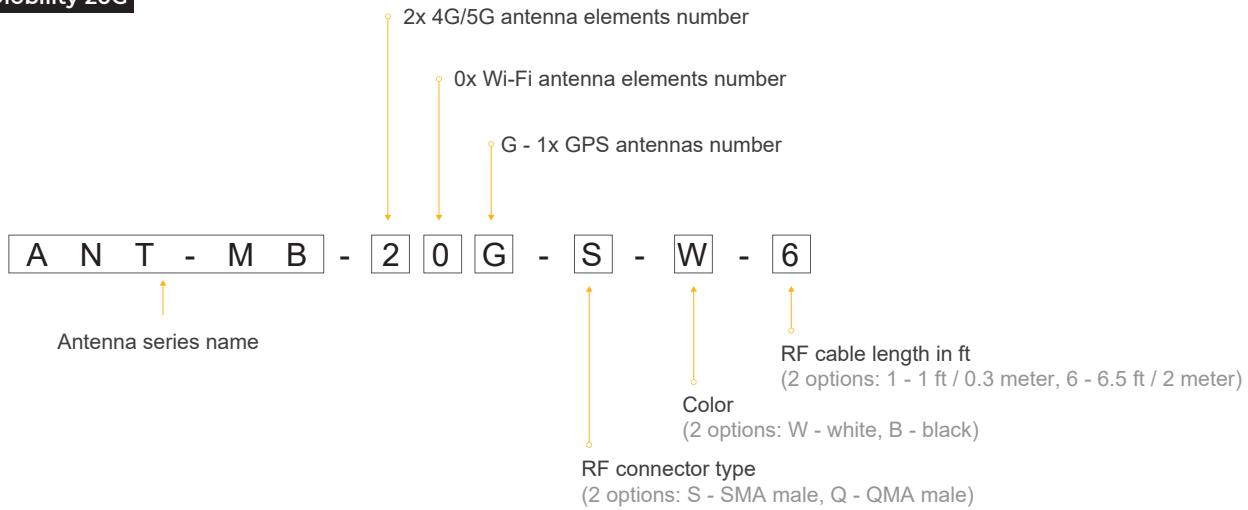

Product Code	Description
ANT-MB-20G-S-W-6	2xLTE/5G, 1xGPS 600-6000MHz, IP68, SMA male, White, 6.5 ft / 2m
ANT-MB-20G-S-B-6	2xLTE/5G, 1xGPS 600-6000MHz, IP68, SMA male, Black, 6.5 ft / 2m
ANT-MB-20G-Q-W-1	2xLTE/5G, 1xGPS 600-6000MHz, IP68, QMA male, White, 1 ft / 0.3m
ANT-MB-20G-Q-B-1	2xLTE/5G, 1xGPS 600-6000MHz, IP68, QMA male, Black, 1 ft / 0.3m

### Extension cable

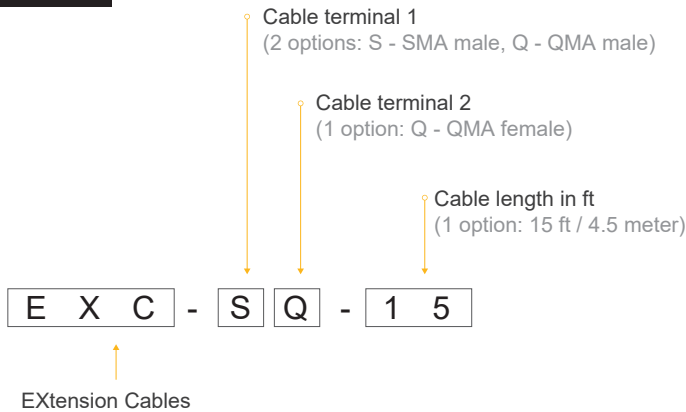

### LTE/GPS elements

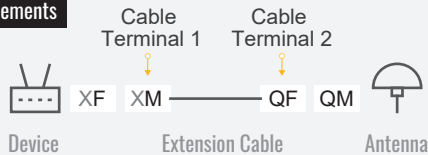

Product Code	Element type	Description
EXC-SQ-15	LTE/GPS elements	Extension coax cable, SMA male to QMA female connector, 15ft / 4.5m
EXC-QQ-15	LTE/GPS elements	Extension coax cable, QMA male to QMA female connector, 15ft / 4.5m

Technical drawing

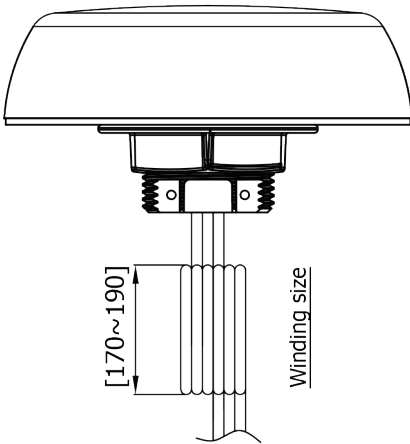
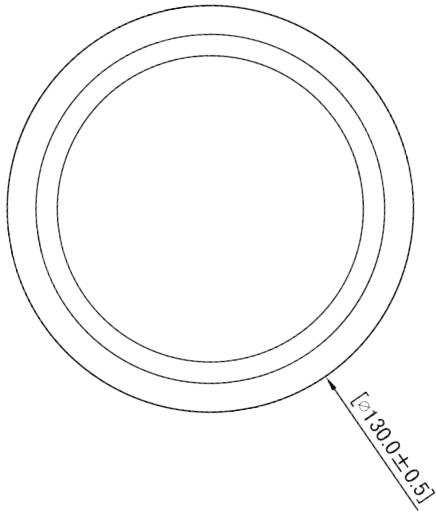

# Mobility 20G

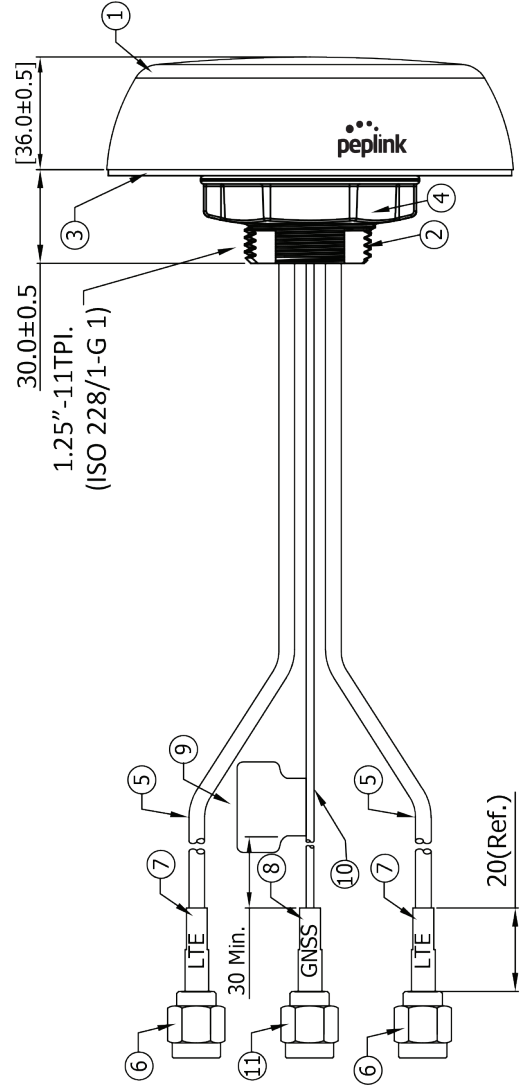

## Index

No.	Description	Qty
1	Antenna Top Cover (PC)	1
2	Antenna Bottom Cover (PC)	1
3	Double sided 3M adhesive pad	1
4	Hexagon NUT (PC)	1
5	Cable CFD-200 (LTE/5G)	2
6	LTE/5G antenna RF connector	2
7	LTE/5G cable marking	2
8	GPS cable marking	1
9	Label	1
10	Cable RG-174 (GPS)	1
11	GPS antenna RF connector	1

LTE/ 5G Antenna VSWR

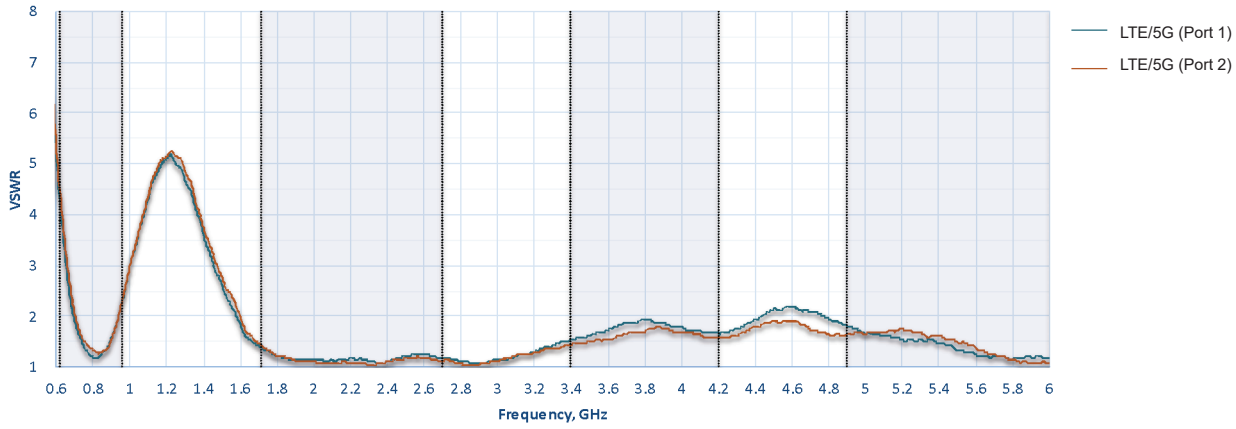

LTE/ 5G Antenna Gain

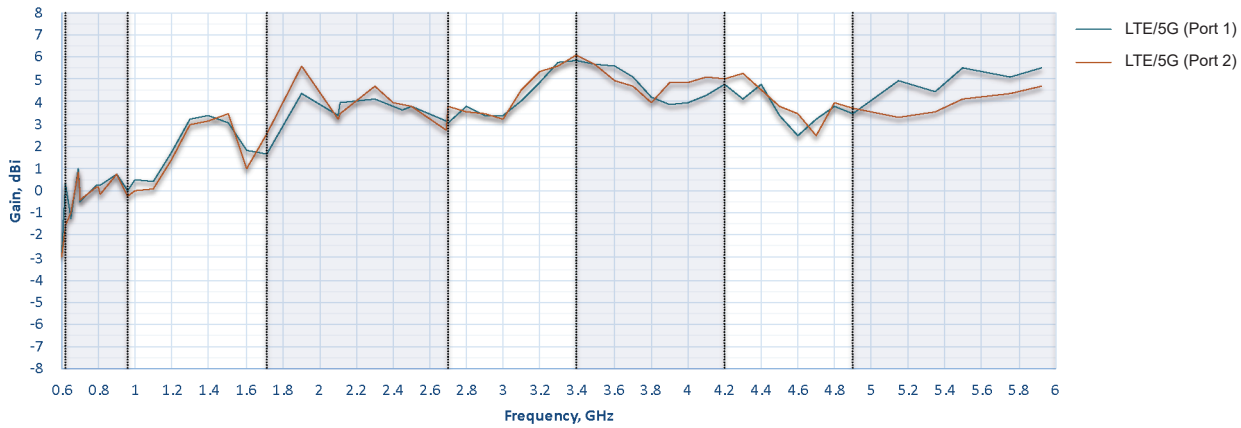

Mobility 20G

## LTE/ 5G Antenna Isolation

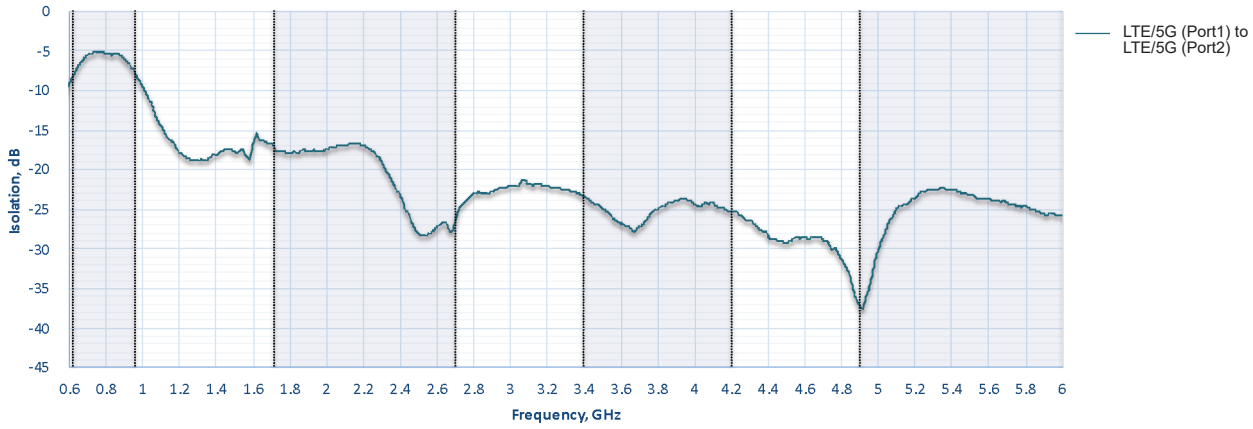

## LTE/ 5G Antenna Efficiency

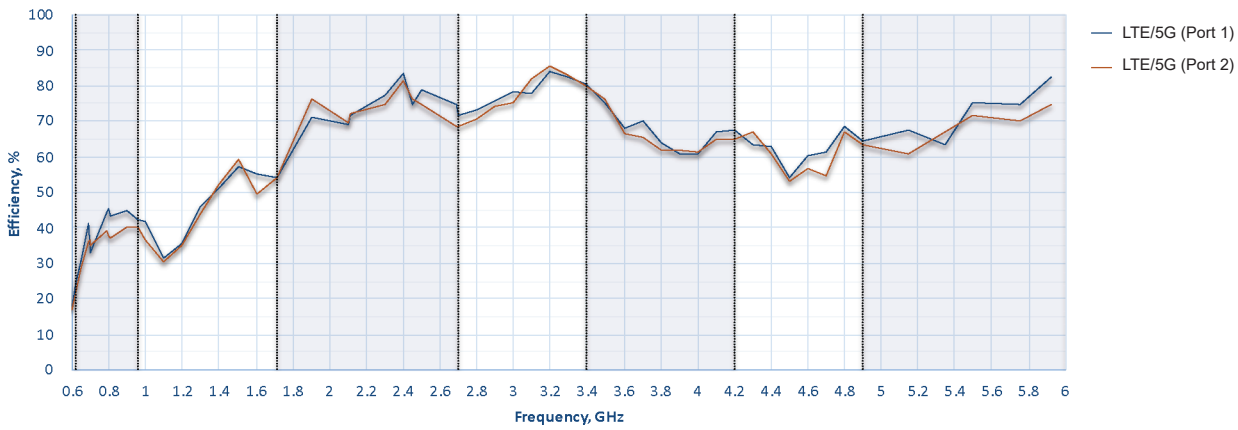

LTE/5G Antenna Radiation patterns (Azimuth)

617-960 MHz

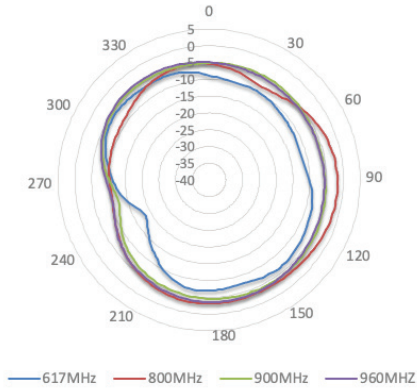

3400-3800 MHz

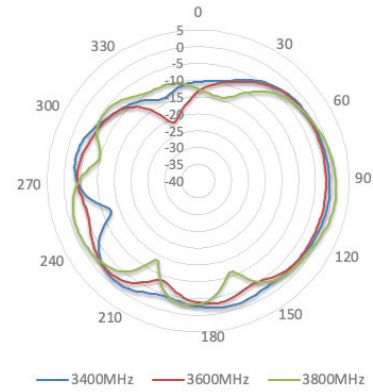

1710-2100 MHz

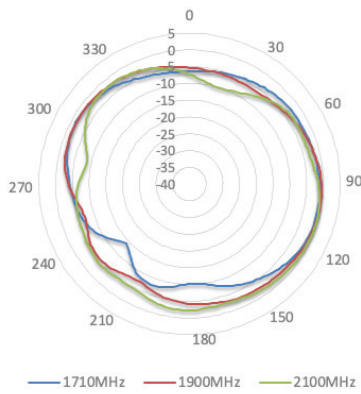

4200-5150 MHz

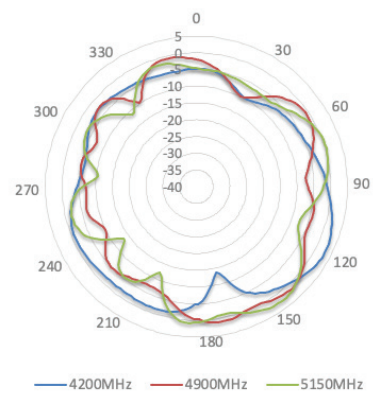

2300-2700 MHz

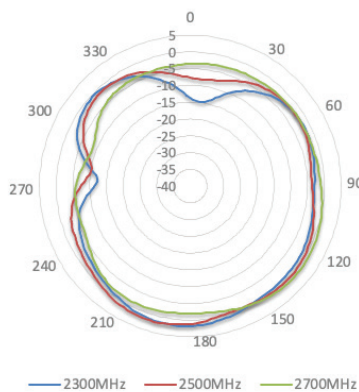

5350-5930 MHz

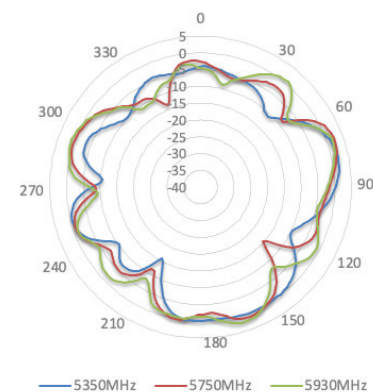

Mobility 20G

LTE/5G Antenna Radiation patterns (Elevation 1)

617-960 MHz

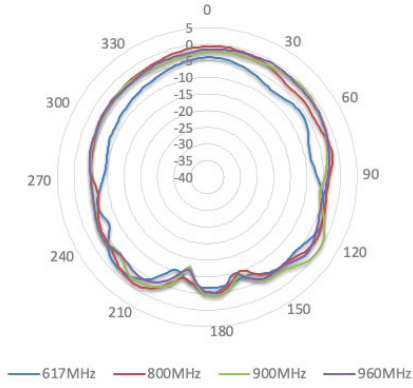

3400-3800 MHz

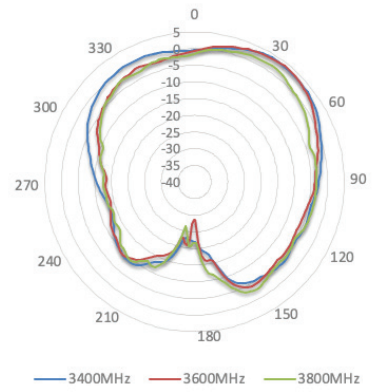

1710-2100 MHz

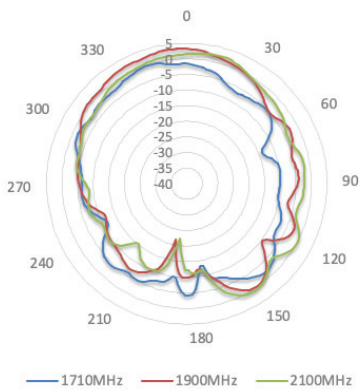

4200-5150 MHz

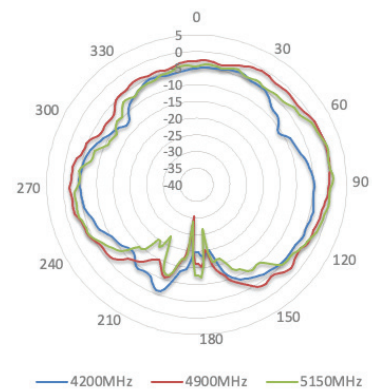

2300-2700 MHz

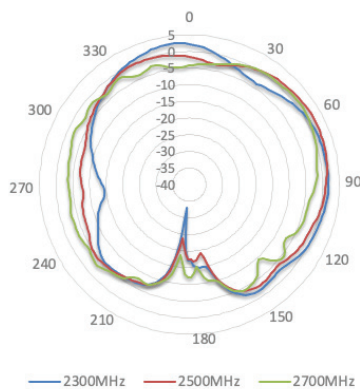

5350-5930 MHz

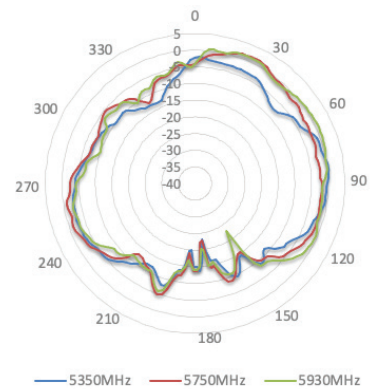

Mobility 20G



LTE/5G Antenna Radiation patterns (Elevation 2)

617-960 MHz

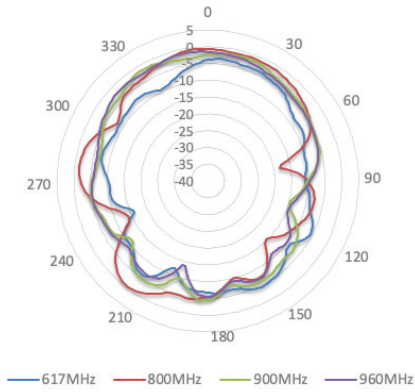

3400-3800 MHz

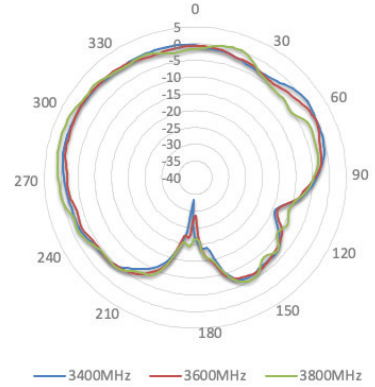

1710-2100 MHz

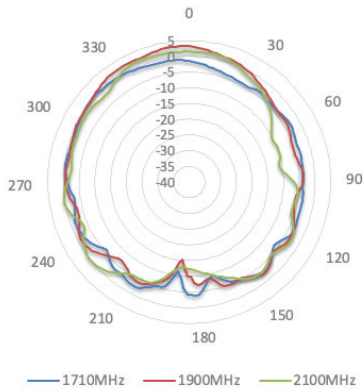

4200-5150 MHz

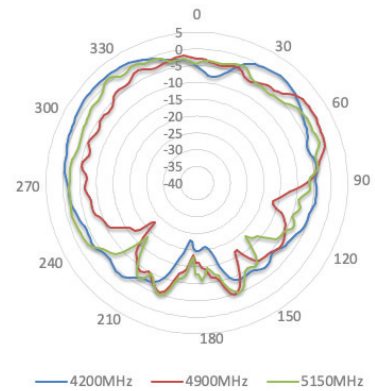

2300-2700 MHz

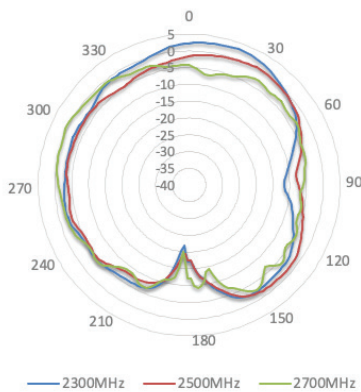

5350-5930 MHz

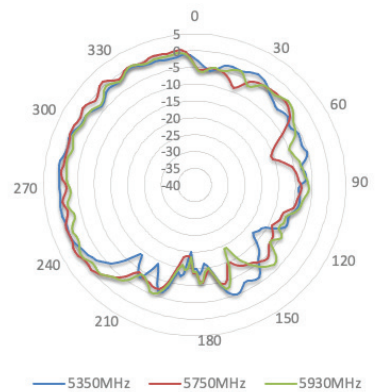

Mobility 20G

## Installation recommendation

### Panel Mount

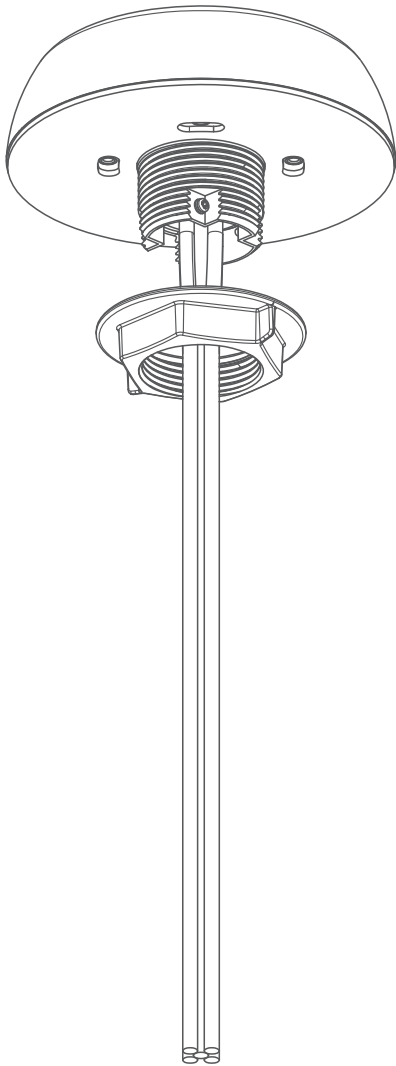

# Mobility 20G

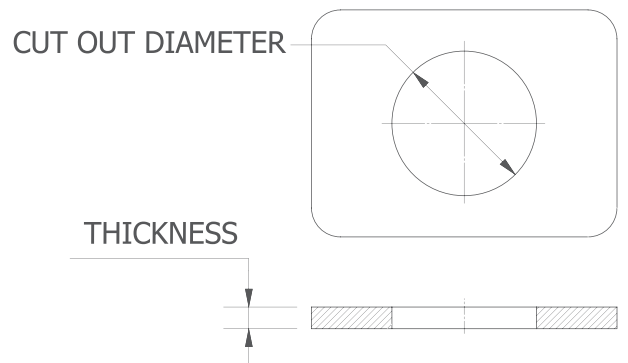

### Notes

- Cover panel surface to protect the paint work. When drilling a hole, start with a small one, then increase it.
- Diameter of the cut out should be 1 11/16" / 43mm. Maximum allowed thickness of the panel - 15mm.
- After drilling, clean up the surface and apply some paint around the hole to prevent corrosion. Attach the antenna.

Installation recommendation

Pole Mount

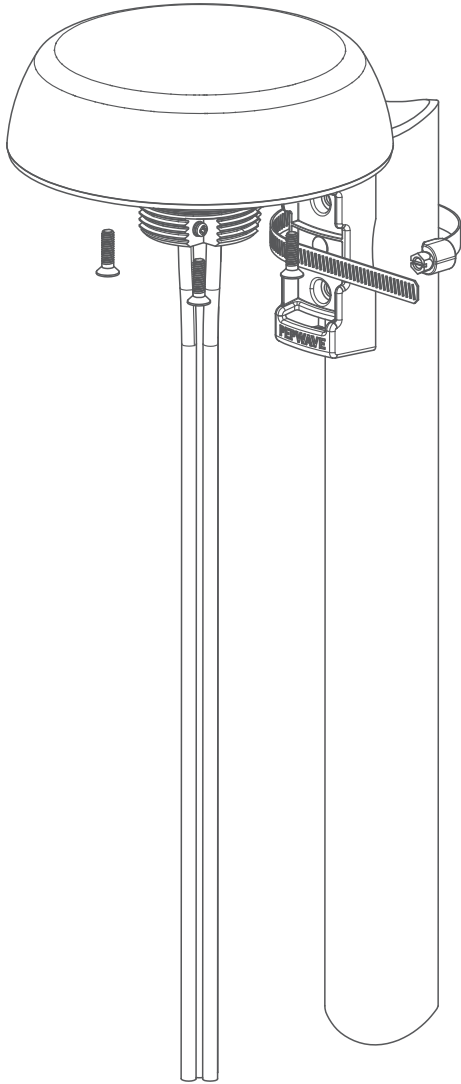

Mobility 20G

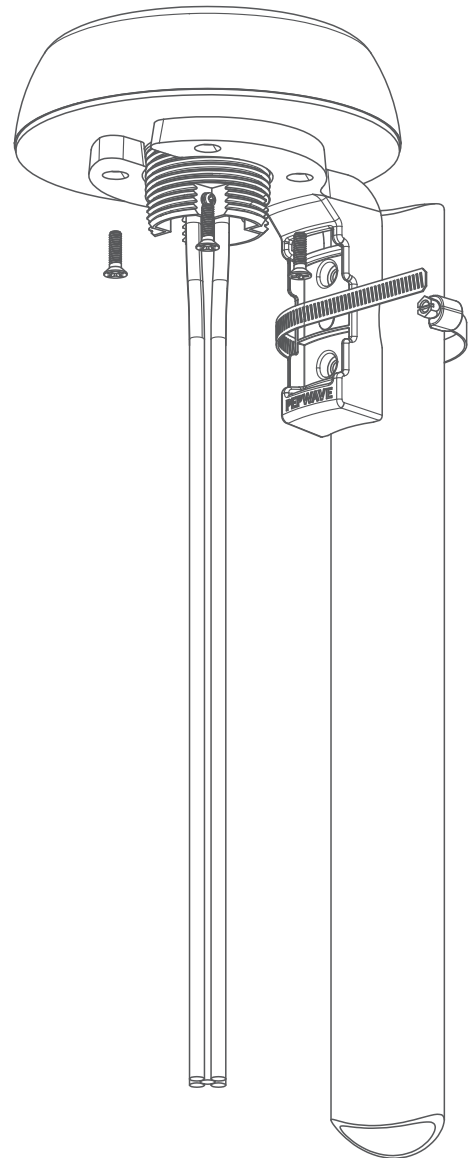

Installation recommendation

Horizontal Pole Mount

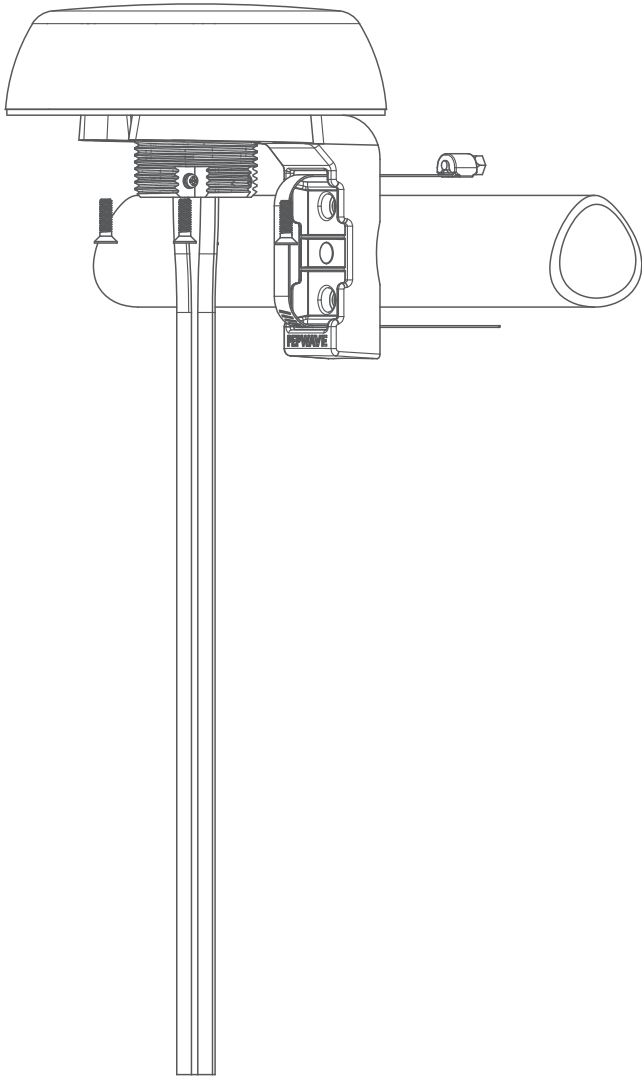

Mobility 20G

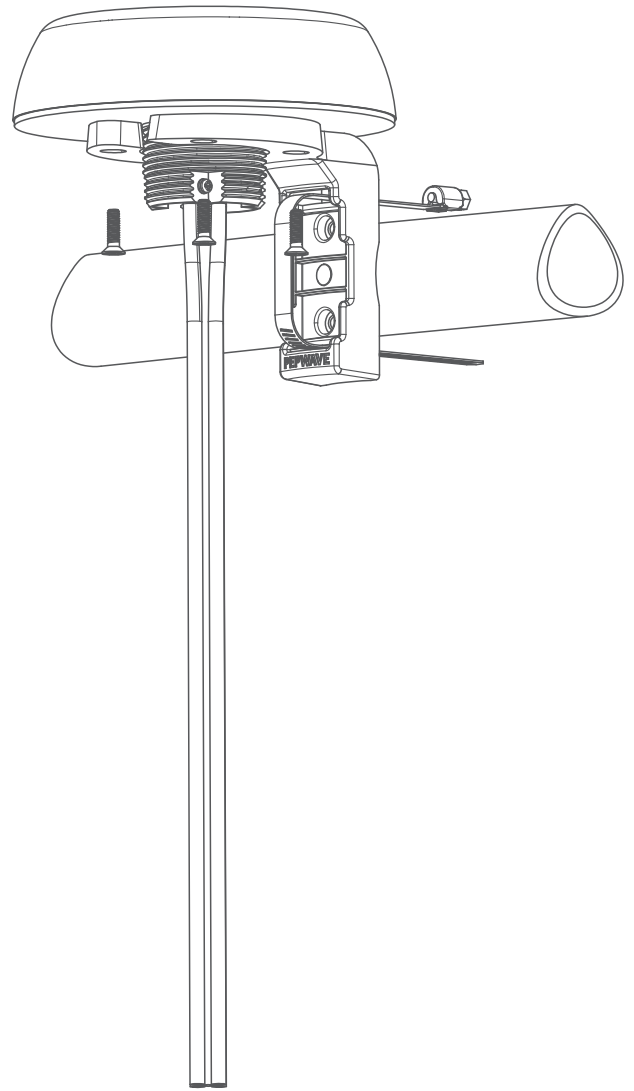

Installation recommendation

Wall Mount

Mobility 20G

